

BLANCO VISION 1 SILGRANIT® Topmount Sink

Made of ultra durable granite composite material, BLANCO SILGRANIT® combines 80% natural granite, with high-quality acrylic for unmatched strength and durability.

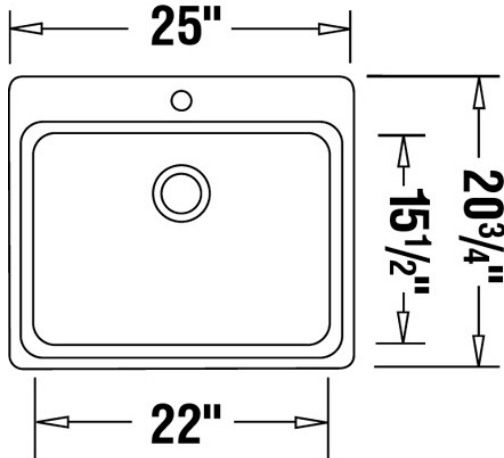

Model No.	Colour	Bowl Depth	
		Main	Secondary
400174	Anthracite	8" (205 mm)	
400364	Café		
401147	Truffle		

Material

BLANCO SILGRANIT®

Durable, patented composite material made of 80% natural granite

Specifications

Minimum Cabinet Size: 27" (685 mm)

Unsurpassed scratch, chip and stain resistance

Heat resistant to temperatures of up to 280°C (536°F)

Fade-proof; solid colour throughout

Rear positioned drain hole for max. usable bowl and cabinet space

Enormous single bowl accommodates bulky items

3.5" (90 mm) stainless steel strainer included

Matching Silgranit® colour faucets and optional accessories available

4 additional knock-out holes for accessories

Template included

Limited Lifetime Warranty

Made in Canada

BLANCO CANADA INC.

9-3909 Nashua Dr., Mississauga, ON L4V 1R3

Tel: 905-612-0554 Toll Free: 1-877-425-2626

Fax: 905-612-9764 Toll Free: 1-877-825-2626

www.blancocanada.com